

GTA 90-01-040  
MAR 2016

# Reconnaissance Smartcard

This card is designed to assist leaders at the section and platoon levels in the planning and execution of reconnaissance tasks



Center for Army Lessons Learned

## DESTRUCTION NOTICE

Destroy by any method that will prevent disclosure of contents or reconstruction of the document.

## Fundamentals

### RECONNAISSANCE

- Ensure continuous reconnaissance
- Do not keep recon assets in reserve
- Orient on the recon objective
- Report all info rapidly and accurately
- Retain freedom to maneuver
- Gain and maintain enemy contact
- Develop the situation rapidly

### SECURITY

- Provide early and accurate warning
- Provide reaction time and maneuver space
- Orient on the protected force, area, or facility
- Perform continuous reconnaissance
- Maintain enemy contact

### MOVEMENT

- Use terrain for cover and concealment
- Dismount vehicles
- Reduce vehicle-related signatures
- Conduct Listening halts at Danger areas
  - Open areas
  - Wooded Areas
  - Urban Areas
- Identify and report lateral or boundary routes

FM 3-98 Ch. 5, ATP 3-20.98 Ch. 2

### MILITARY ASPECTS OF TERRAIN

- O**bservation/fields of fire
- A**venues of approach
- K**ey terrain
- O**bstacles
- C**over/concealment

ATP 3-34.80 Ch.4

### PERSONNEL SOLDIER LOADS

- C**ompass
- W**eapon
- O**ptics
- R**adio
- M**ap
- S**easonal/sustainment

ATP 3-20.97 Ch.5

## Route Recon Tasks

- Find, report, and—based on engagement criteria—clear within capabilities all enemy forces that can influence movement along the route.
- Reconnoiter and determine the trafficability of the route.
- Reconnoiter all terrain the enemy can use to affect movement along the route.
- Reconnoiter all built-up areas along the route.
- Reconnoiter all lateral routes.
- Inspect and classify all bridges on the route.
- Reconnoiter defiles along the route. Clear them of enemy and obstacles (within capability), or locate a bypass.
- Locate fords or crossing sites near all bridges on the route.
- Inspect and classify all overpasses, underpasses, and culverts.
- Locate and clear (within capability) all mines, obstacles, and barriers on the route.
- Locate bypasses around built-up areas, obstacles, and contaminated areas.
- Report route information.

FM 3-98 Ch. 5

## Area/Zone Recon Tasks

- Find and report all enemy forces within the area/zone.
- Based on engagement criteria, clear all enemy forces in the designated area within the capability of the unit conducting reconnaissance.
- Determine the trafficability of all terrain in the zone, including built-up areas.
- Locate and determine the extent of all contaminated areas in the area/zone.
- Inspect and classify all bridges within the area/zone.
- Locate fords or crossing sites within the area/zone.
- Inspect and classify all overpasses, underpasses, and culverts.
- Locate and clear all mines, obstacles, and barriers in the area/zone (within capability).
- Report reconnaissance information.

FM 3-98 Ch. 5

## Principles for Selecting Observation Posts

- B** – Blend in with the surrounding area. Does the site look natural? Does it attract unwanted attention?
- L** – Low-to-the-ground construction techniques are used. Does the site provide protection against small-arms and direct weapons fire?
- U** – Unexpected sites should be used. Do enemy forces expect to look out the window, or the small hole in the wall?
- E** – Evacuation routes are planned during site selection. Where is the link-up location with friendly forces?
- S** – Avoid silhouetting of the site by using the sides of hills, not the crests. Can a sniper see a Soldier silhouetted against the skyline, wall, or other object?

ATP 3-20.98 Ch. 4

### OCCUPYING THE OBSERVATION POST (OP)

- Establish overwatch of the general OP site
- Recon the OP
- Establish security overwatch
- Select hide and fighting positions
- Establish fighting positions
- Develop and validate sector sketches

ATP 3-20.98 pg. 4-11

### MANNING THE OBSERVATION POST

- Observe the area
- Report information
- Protect yourself
- Call for and adjust fire

ATP 3-20.98 Ch. 4

## Effect of Movement on Route Reconnaissance

When the platoon has to move:	The mission becomes:
Rapid	Focused on a few key pieces of information/tasks
Deliberate	Slow, detailed, broad-based to accomplish a number of tasks
Stealth	Undetected, time-consuming, primarily dismounted operations to minimize threat contact
Forceful	Primarily mounted, fast-paced, prepared to engage the threat; not as concerned with being observed.

FM 3-98 Ch. 4

## Call for Fire

**Element 1:** "FDC/FSO call sign" this is "Observer call sign"

**Element 2:** Warning Order (Adjust Fire/Fire For Effect/Immediate Suppression)

**Element 3:** Target location (Grid or direction [mils]/distance [meters])

**Note:** Recommend using grid method unless in a static position and the observer location is known.

**Element 4:** Target description (number, type, and disposition of target)

**Element 5:** Method of engagement (optional)  
Includes requested shell/fuze combination (example: HE/VT) and sheaf (example: converged or open sheaf)

**Note:** This is requested. The fire detection center (FDC) has final determination.

**Element 6:** Method of control (optional)  
(Examples: At My Command or Time on Target)

**Initial Call For Fire is sent in 3 transmissions:**

1. Elements 1 and 2
2. Element 3
3. Elements 4-6

After initial transmission, transmit only adjustments or changes to initial call for fire.

ATP 3-09.30 Ch. 4

## Local Security Measures

### Active

- Employing platoon observation posts
- Employ patrols to cover perimeter and dead space
- Establish threat levels and procedures
- Enforce stand-to
- Enforce proper communications procedures

### Passive

- Employing camouflage
- Enforcing noise and light discipline
- Employ sensors for surveillance of the area around the unit

ATP 3-20.98 Ch. 4

## 9 Line MEDEVAC

**Line 1:** Location of pickup site (Grid)

**Line 2:** Radio frequency and call sign

**Line 3:** Number of patients by precedence

**A** - Urgent **B** - Urgent surgical  
**C** - Priority **D** - Routine

**Line 4:** Special equipment required

**A** - None **B** - Hoist  
**C** - Extraction equipment **D** - Ventilator

**Line 5:** Number of patients by type

**L** - Litter **A** - Ambulatory

**Line 6:** Security of pickup site

**N** - No enemy troops in area  
**P** - Possibly enemy troops in area (approach with caution)  
**E** - Enemy troops in area (approach with caution)  
**X** - Enemy troops in area (armed escort required)

**Line 7:** Method of marking pickup site

**A** - Panels **B** - Pyrotechnic signal  
**C** - Smoke signal **D** - None **E** - Other

**Line 8:** Patient nationality and status

**A** - US military **B** - US citizen **C** - Non-US military  
**D** - Non-US citizen **E** - enemy prisoner of war

**Line 9:** CBRN contamination

**C** - Chemical **B** - Biological  
**R** - Radiologic **N** - Nuclear

ATP 4-02.2 Ch. 5

## Troop Leading Procedures

**Step 1 –** Receive the mission

- Identify recon or security tasks
- Conduct confirmation brief to higher
- Allocate the available time

**Step 2 –** Issue a warning order

- Determine tentative course of action
- Time and place for issuing the OPORD
- Timeline for the operation

**Step 3 –** Make a tentative plan

- Use METT-TC to conduct mission analysis
- Develop course of action

**Step 4 –** Initiate movement

**Step 5 –** Conduct reconnaissance

**Step 6 –** Complete the plan

- Prepare overlays (digital and/or analog)
- Refine indirect fire target list
- Coordinate sustainment and C2 requirements
- Update the tentative plan

**Step 7 –** Issue the order

**Step 8 –** Supervise and refine  
Conduct rehearsals

ATP 3-20.97 Ch. 2

## Weapons Data

### TYPE MAX EFF RANGE (m)

M4	500 m (point) / 600 m (area)
M16A4	550 m (point) / 600 m (area)
M203/320	150 m (point) / 350 m (area)
M249	600 m (point) / 800 m (area)
M136 (AT4)	300 m
M98A1 (Javelin)	2,000 m
MK 19	1,500 m (point) / 2,212 m (area)
M3 RAAWS	700 m
M240B	1,100 m (area) / 600 m (graze)
M2 (.50 cal)	1,830 m (area) / 700 m (graze)
TOW	3,750 m
M119 (105 mm)	11,500 m
MGS	2,000 m
M1 Tank	1,500 m to 2,500 m (optimum)
25mm BFV	2,500 m
M109A6 (155 mm)	21,700 m
M777 (155 mm)	22,200 m

### Mortar (HE only) MIN / MAX Range

60 mm	70 m / 3,489 m
81 mm (M252)	80m 5,800 m
81 mm (M29A1)	70 m / 4,600 m
120 mm	200m 7,200 m

### Artillery / Mortar Length and Width

2 x 60 mm	60 m x 30 m
4 x 81 mm (M252)	150 m x 50 m
4 x 81 mm (M29A1)	140 m x 40 m
2 x 120 mm	150 m x 75 m
3 x 105 mm	105 m x 35 m
3 x 105 mm	105 m x 35 m
3 x 155 mm	150 m x 50 m

## Percentage of Slope

### GROUND SLOPE EXPRESSED IN DEGREES

The approximate slope angle may be calculated by multiplying the gradient by 57.3. This method is reasonably accurate for slope angles under 20 degrees.

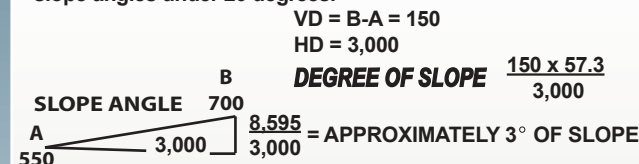

### GROUND SLOPE EXPRESSED AS PERCENTAGE

To determine the percent of ground slope, divide the vertical distance (VD) by the horizontal distance (HD) and multiply by 100.

$$\text{PERCENT OF SLOPE} = \frac{\text{VD}}{\text{HD}} \times 100$$

Vertical distance is the difference in field elevation between the two ends of the landing site. Always round number up to the next whole number.

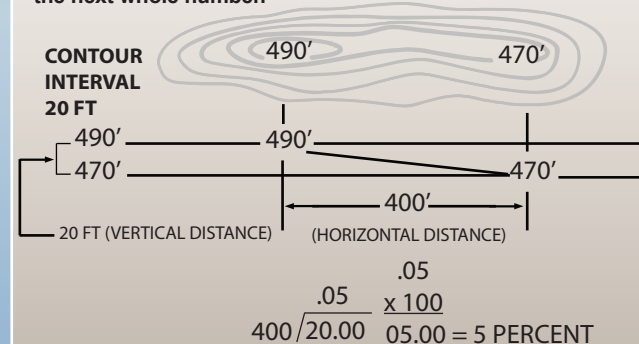

## Curve Measurement Formula Method

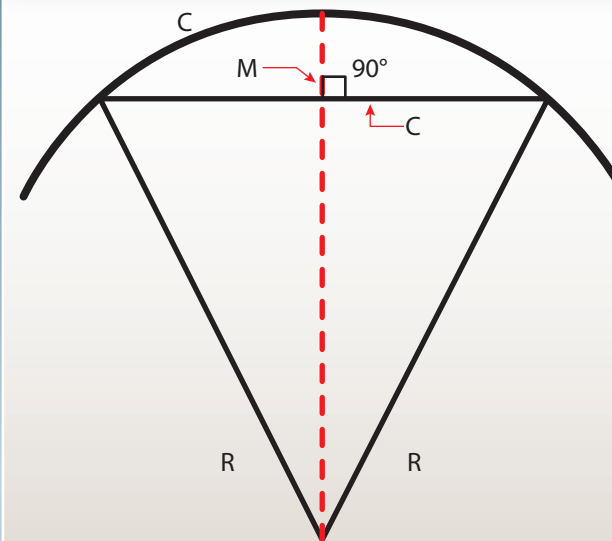

$$R = \frac{C^2}{8M} + \frac{M}{2}$$

R = Radius of the curve

C = Distance from the centerline of the road to the centerline of the road at the outer extremities of the curve

M = Perpendicular distance from the center of the tape to the centerline of the road

## Overhead Clearance in Tunnels

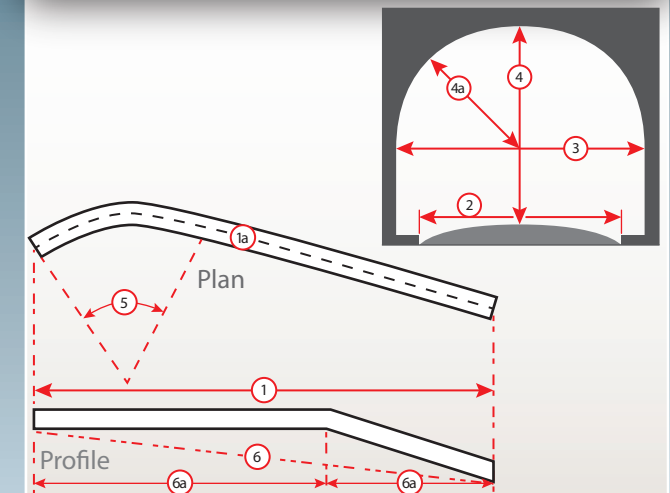

- Portal-to-portal length of tunnel
- Effective width of the traveled way, curb to curb
- Horizontal clearance (minimum width of the tunnel bore measured at least 4 feet above the traveled way)
- Overhead clearance (minimum distance between the top of the traveled way and the lower edge of the tunnel ceiling)
- Radius of curvature of the traveled way, either measured or estimated
- Gradient (percentage of rise of the traveled way between portals)
- Change in gradient within the tunnel (percentage of rise each way from break of grade)
- Centerline distance of tunnel
- Rise of tunnel arch (radius of curved portion)
- or any obstruction below the ceiling, such as trolley wires of electric light wires

## CAS 9-Line Brief

Must state "I am not JTAC qualified."

**Line 1:** IP / BP.....N/A unless JTAC

**Line 2:** Heading.....N/A unless JTAC  
Offset.....N/A unless JTAC

**Line 3:** Distance.....N/A unless JTAC

**Line 4:** Target Elevation..... Given in feet mean sea level

**Line 5:** Target Description.....Number, type, and disposition of target (specific enough for the aircrew to recognize)

**Line 6:** Target Location..... Grid

**Line 7:** Mark Type/Terminal Guidance.....Mark: smoke, laser, IR, other, or none (Note: if laser, provide laser code)

**Line 8:** Friendlies.....Cardinal/sub-cardinal heading (N, NE, E, SE, S, SW, W, NW) and distance (meters)

**Line 9:** Egress.....Instructions to exit target area (typically "at pilot's discretion")

**Line 10:** Remarks.....Laser target line, pointer target line; desired type/number of ordnance and/or weapons effects (if not previously coordinated); surface-to-air threat, location, and type of SEAD

### Restrictions

Final attack headings/attack directions, ACA, danger close and initials (if applicable), Time on Target/Time to Target

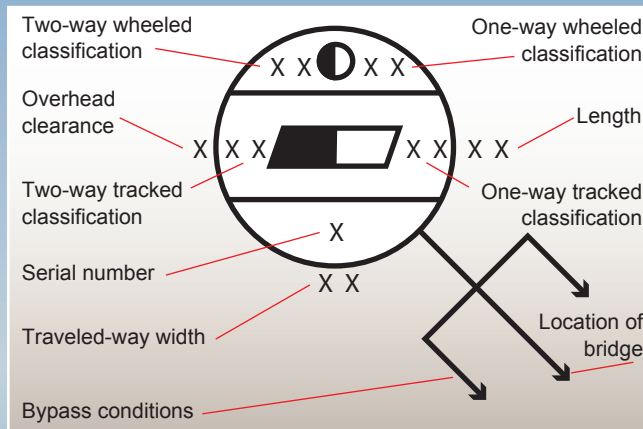

## Measuring Stream Width With a Compass

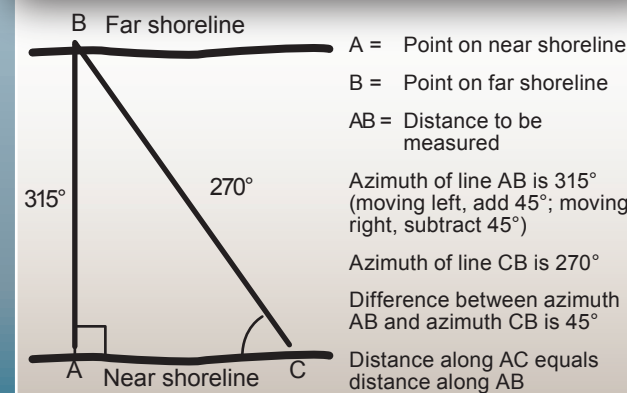

## Dimensions Required for Streams

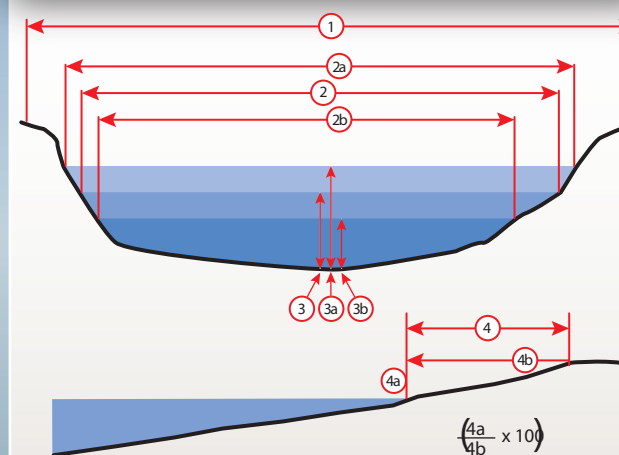

- Width of streambed from bank
- Actual width of water, measured at normal stage (maximum width 2a and minimum width 2b are estimated, based on local observations or records of high water and low water)
- Actual depth of stream at normal water level
- Slope of approaches (slope of stream banks through which approach roads are cut)
- Estimated maximum water depth, based on local observations or records
- Estimated minimum water depth, based on local observations or records

## Overhead Clearance Measurements

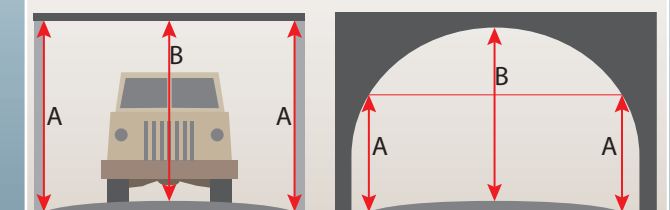
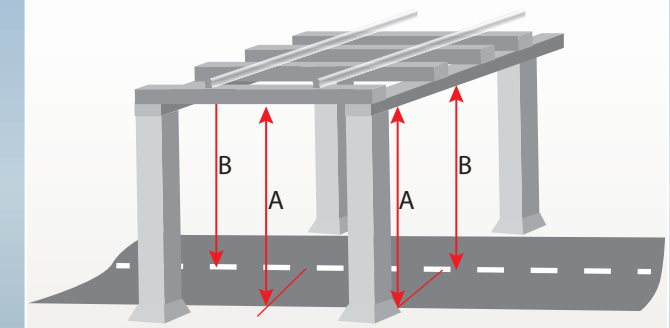

- A = Minimum measurement (always taken at the outside edge of the traveled way)
- B = Maximum measurement (always taken at the center of the road)